

FIRE SAFETY CLOSURES

FIRE RATED COUNTER SHUTTERS

Model ERC10 and Model ERC20 (integral frame and sill)



PREPAREDNESS IS EVERYTHING WHEN SECONDS COUNT

SUPERIOR SEPARATION AND PROTECTION

UL labeled for up to 3 hours, Fire-Rated Counter Shutters are custom-built to exact opening specifications using compact guides, slats, brackets and hoods for a smooth profile. When compact door components are desired, these rated shutters quickly and reliably close to the sill.

GET UL LABELS FOR UP TO 1½ HOURS ON INTEGRAL FRAME AND SILL UNITS

For a custom appearance and a quick install, slip-in units easily set into existing walls.

FAILSAFE ACTIVATION

AlarmGard® shutters may be integrated to the building fire alarm control panel or they may simply be activated by local smoke detectors. Once notified by electrical signal, they close at a safe and reliable rate.

ENHANCED SMOKE PROTECTION AVAILABLE

Optional SmokeShield® smoke and draft control conforms to UL1784 and assures that smoke will be compartmentalized with the fire and not spread quickly throughout the facility, allowing safe egress for occupants.

FIRE SAFETY CLOSURES **FIRE RATED COUNTER SHUTTERS**

Model ERC10 and Model ERC20 (integral frame and sill)

STANDARD COMPONENT MATERIALS AND FINISHES

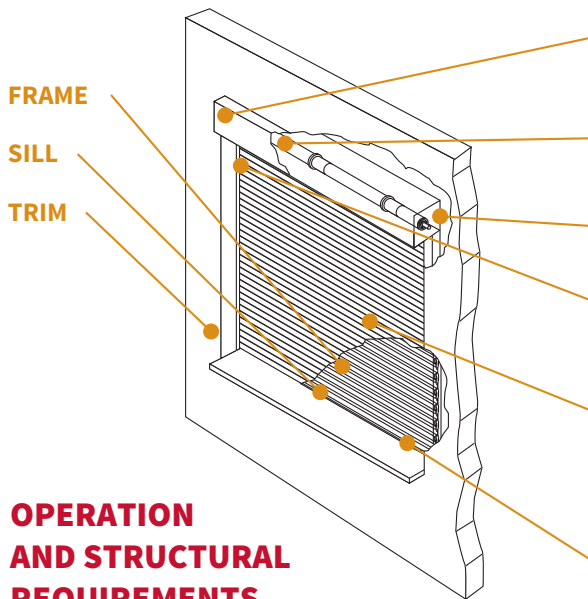

OPERATION AND STRUCTURAL REQUIREMENTS

Chain hoist, crank and advanced motor operated selections allow you to further customize our product to fit your needs. Our coiling fire protectives are attached to the structural vertical jamb of the opening and supported by the guides. No additional support required unless hood supports are mandated by larger opening width.

HOOD - Galvanized steel with GalvaNex™ polyester enamel finish to match curtain. Encloses the curtain and provides weather resistance at the head of the door.

COUNTER-BALANCE SHAFT - Steel. Supports curtain and contains torsion springs for assisting operation.

BRACKETS - Steel with powder coating to match curtain. Bolt to guide assembly and support counter-balance shaft and curtain.

GUIDES - Steel with powder coating to match curtain. Side rail assemblies bolt to the wall (spacing per UL procedure) and support the entire weight of the unit.

CURTAIN - Galvanized steel with GalvaNex polyester enamel finish in Gray or Tan. Interlocking roll-formed flat-faced slats with galvanized steel endlocks riveted to the ends of alternate slats to maintain curtain alignment and prevent wear.

BOTTOM BAR - Steel with SpectraShield® powder coating to match curtain. Reinforcing member attached to the bottom of the curtain with a vinyl astragal seal. Lock mechanisms available.

WITH INTEGRAL FRAME AND SILL

HOOD - Stainless steel.

*All stainless steel is 300 series in #4 finish.

BRACKETS - Stainless steel.

CURTAIN - Stainless steel.

BOTTOM BAR - Stainless steel.

FRAME - Welded stainless steel head and jambs. Guide groove is incorporated into jamb design.

SILL - Stainless steel for a seamless, custom look.

TRIM - Stainless steel jamb trim angles. Head trim optional.

OPTIONAL MATERIALS AND FINISHES

- ▶ Stainless steel - 300 series in #4 finish
- ▶ SpectraShield® Powder Coating in more than 180 colors

Brackets, Guides and Bottom Bar

- ▶ Hot-dip galvanizing on steel components
- ▶ Zinc-enriched, corrosion-resistant powder coating in Gray

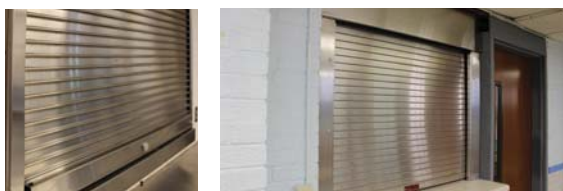

CUSTOM-DESIGNED SOLUTIONS

Our experienced Architectural Design Support Team can customize our products to fit your specific application. Call 800.294.4358 ext. 1280 or email ads@cooksondoor.com.